

(12) INTERNATIONAL APPLICATION PUBLISHED UNDER THE PATENT COOPERATION TREATY (PCT)

(19) World Intellectual Property  
Organization  
International Bureau



(43) International Publication Date  
18 March 2004 (18.03.2004)

PCT

(10) International Publication Number  
WO 2004/023014 A2

(51) International Patent Classification<sup>7</sup>: F16L

RING, Lev [US/US]; 14126 Heatherhill Place, Houston, TX 77077 (US). MENCHACA, Jose [US/US]; 9800 Pagewood Lane, Number 210, Houston, TX 77042 (US).

(21) International Application Number:  
PCT/US2003/025716

(74) Agent: MATTINGLY, Todd; Haynes and Boone, LLP; 1000 Louisiana, Suite 4300, Houston, TX 77002-5012 (US).

(22) International Filing Date: 18 August 2003 (18.08.2003)

(25) Filing Language: English

(26) Publication Language: English

(81) Designated States (*national*): AE, AG, AL, AM, AT, AU, AZ, BA, BB, BG, BR, BY, BZ, CA, CH, CN, CO, CR, CU, CZ, DE, DK, DM, DZ, EC, EE, ES, FI, GB, GD, GE, GH, GM, HR, HU, ID, IL, IN, IS, JP, KE, KG, KP, KR, KZ, LC, LK, LR, LS, LT, LU, LV, MA, MD, MG, MK, MN, MW, MX, MZ, NO, NZ, OM, PI, PL, PT, RO, RU, SC, SD, SE, SG, SK, SL, TJ, TM, TN, TR, TT, TZ, UA, UG, US, UZ, VC, VN, YU, ZA, ZM, ZW.

(30) Priority Data:  
60/412,371 9 September 2002 (09.09.2002) US

(71) Applicant (*for all designated States except US*): ENVEN-  
TURE GLOBAL TECHNOLOGY [US/US]; 16200 A Park  
Row, Houston, TX 77084 (US).

(72) Inventors; and

(84) Designated States (*regional*): ARIPO patent (GH, GM, KE, LS, MW, MZ, SD, SL, SZ, TZ, UG, ZM, ZW), Eurasian patent (AM, AZ, BY, KG, KZ, MD, RU, TJ, TM),

(75) Inventors/Applicants (*for US only*): COSTA, Scott [US/US]; 2011 Willow Point, Kingwood, TX 77330 (US).

[Continued on next page]

(54) Title: THREADED CONNECTION FOR EXPANDABLE TUBULARS

(57) Abstract: A threaded connection for expandable tubulars.

WO 2004/023014 A2

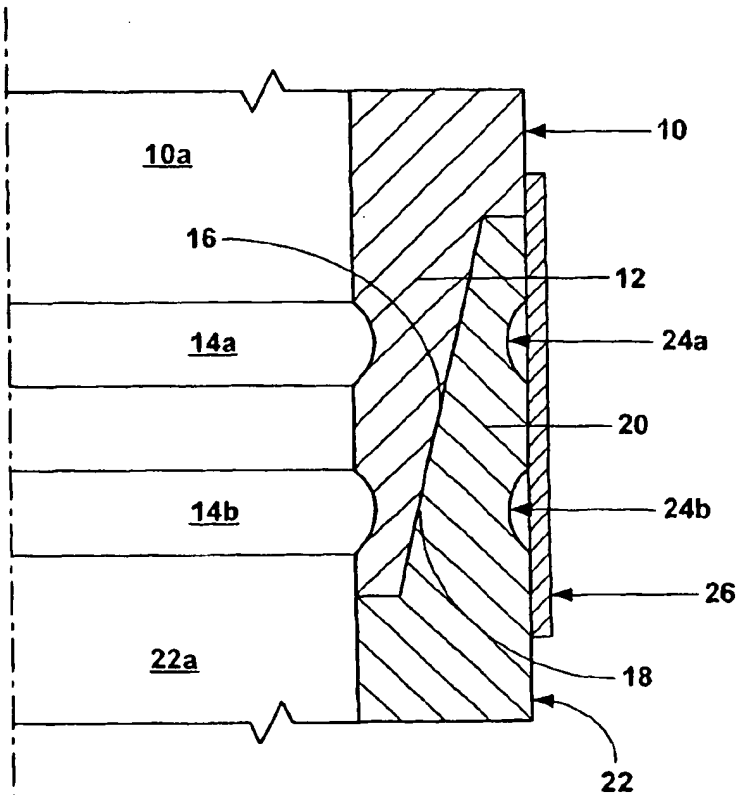



European patent (AT, BE, BG, CH, CY, CZ, DE, DK, EE, ES, FI, FR, GB, GR, HU, IE, IT, LU, MC, NL, PT, RO, SE, SI, SK, TR). OAPI patent (BF, BJ, CF, CG, CI, CM, GA, GN, GQ, GW, ML, MR, NE, SN, TD, TG).

**Published:**

— without international search report and to be republished upon receipt of that report

**Declaration under Rule 4.17:**

— of inventorship (Rule 4.17(iv)) for US only

For two-letter codes and other abbreviations, refer to the "Guidance Notes on Codes and Abbreviations" appearing at the beginning of each regular issue of the PCT Gazette.

**THREADED CONNECTION FOR EXPANDABLE TUBULARS****Cross Reference T Related Applications**

[001] The present application claims the benefit of the filing dates of (1) U.S. provisional patent application serial no. 60/412,371, attorney docket no 25791.129, filed on 9/20/2002, the disclosure of which is incorporated herein by reference.

[002] The present application is related to the following: (1) U.S. patent application serial no. 09/454,139, attorney docket no. 25791.03.02, filed on 12/3/1999, (2) U.S. patent application serial no. 09/510,913, attorney docket no. 25791.7.02, filed on 2/23/2000, (3) U.S. patent application serial no. 09/502,350, attorney docket no. 25791.8.02, filed on 2/10/2000, (4) U.S. patent no. 6,328,113, (5) U.S. patent application serial no. 09/523,460, attorney docket no. 25791.11.02, filed on 3/10/2000, (6) U.S. patent application serial no. 09/512,895, attorney docket no. 25791.12.02, filed on 2/24/2000, (7) U.S. patent application serial no. 09/511,941, attorney docket no. 25791.16.02, filed on 2/24/2000, (8) U.S. patent application serial no. 09/588,946, attorney docket no. 25791.17.02, filed on 6/7/2000, (9) U.S. patent application serial no. 09/559,122, attorney docket no. 25791.23.02, filed on 4/26/2000, (10) PCT patent application serial no. PCT/US00/18635, attorney docket no. 25791.25.02, filed on 7/9/2000, (11) U.S. provisional patent application serial no. 60/162,671, attorney docket no. 25791.27, filed on 11/1/1999, (12) U.S. provisional patent application serial no. 60/154,047, attorney docket no. 25791.29, filed on 9/16/1999, (13) U.S. provisional patent application serial no. 60/159,082, attorney docket no. 25791.34, filed on 10/12/1999, (14) U.S. provisional patent application serial no. 60/159,039, attorney docket no. 25791.36, filed on 10/12/1999, (15) U.S. provisional patent application serial no. 60/159,033, attorney docket no. 25791.37, filed on 10/12/1999, (16) U.S. provisional patent application serial no. 60/212,359, attorney docket no. 25791.38, filed on 6/19/2000, (17) U.S. provisional patent application serial no. 60/165,228, attorney docket no. 25791.39, filed on 11/12/1999, (18) U.S. provisional patent application serial no. 60/221,443, attorney docket no. 25791.45, filed on 7/28/2000, (19) U.S. provisional patent application serial no. 60/221,645, attorney docket no. 25791.46, filed on 7/28/2000, (20) U.S. provisional patent application serial no. 60/233,638, attorney docket no. 25791.47, filed on 9/18/2000, (21) U.S. provisional patent application serial no. 60/237,334, attorney docket no. 25791.48, filed on 10/2/2000, (22) U.S. provisional patent application serial no. 60/270,007, attorney docket no. 25791.50, filed on 2/20/2001, (23) U.S. provisional patent application serial no. 60/262,434, attorney docket no. 25791.51, filed on 1/17/2001, (24) U.S. provisional patent application serial no. 60/259,486, attorney docket no. 25791.52, filed on 1/3/2001, (25) U.S. provisional patent application serial no. 60/303,740, attorney docket no. 25791.61, filed on 7/6/2001, (26) U.S. provisional patent application serial no. 60/313,453, attorney docket no. 25791.59, filed on 8/20/2001, (27) U.S. provisional patent application serial no. 60/317,985, attorney docket no. 25791.67, filed on 9/6/2001, (28) U.S. provisional patent application serial no. 60/3318,386, attorney docket no. 25791.67.02, filed on 9/10/2001, (29) U.S. utility patent application serial no. 09/969,922, attorney docket no. 25791.69, filed on 10/3/2001, (30) U.S. utility

patent application serial no. 10/016,467, attorney docket no. 25791.70, filed on 12/10/2001, (31) U.S. provisional patent application serial no. 60/343,674, attorney docket no. 25791.68, filed on 12/27/2001, (32) U.S. provisional patent application serial no. 60/346,309, attorney docket no. 25791.92, filed on 1/7/2002, (33) U.S. provisional patent application serial no. 60/372,048, attorney docket no. 25791.93, filed on 4/12/2002, (34) U.S. provisional patent application serial no. 60/380,147, attorney docket no. 25791.104, filed on 5/6/2002, (35) U.S. provisional patent application serial no. 60/387,486, attorney docket no. 25791.107, filed on 6/10/2002, (36) U.S. provisional patent application serial no. 60/387,961, attorney docket no. 25791.108, filed on 6/12/2002, (37) U.S. provisional patent application serial no. 60/394,703, attorney docket no. 25791.90, filed on 6/26/2002, (38) U.S. provisional patent application serial no. 60/397,284, attorney docket no. 25791.106, filed on 7/19/2002, (39) U.S. provisional patent application serial no. 60/398,061, attorney docket no. 25791.110, filed on 7/24/2002, (40) U.S. provisional patent application serial no. 60/405,610, attorney docket no. 25791.119, filed on 8/23/2002, (41) U.S. provisional patent application serial no. 60/405,394, attorney docket no. 25791.120, filed on 8/23/2002, (42) U.S. provisional patent application serial no. 60/412,177, attorney docket no. 25791.117, filed on 9/20/2002, (43) U.S. provisional patent application serial no. 60/412,653, attorney docket no. 25791.118, filed on 9/20/2002, (44) U.S. provisional patent application serial no. 60/412,544, attorney docket no. 25791.121, filed on 9/20/2002, (45) U.S. provisional patent application serial no. 60/412,187, attorney docket no. 25791.128, filed on 9/20/2002, (46) U.S. provisional patent application serial no. 60/412,196, attorney docket no. 25791.127, filed on 9/20/2002, (47) U.S. provisional patent application serial no. 60/412,542, attorney docket no. 25791.102, filed on 9/20/2002, (48) U.S. provisional patent application serial no. 60/412,487, attorney docket no. 25791.112, filed on 9/20/2002, (49) U.S. provisional patent application no. 60/412,488, attorney docket no. 25791.114, filed on 9/20/2002, the disclosures of which are incorporated herein by reference.

#### **Background of the Invention**

**[003]** This invention relates generally to oil and gas exploration, and in particular to forming and repairing wellbore casings to facilitate oil and gas exploration.

**[004]** Conventionally, when a wellbore is created, a number of casings are installed in the borehole to prevent collapse of the borehole wall and to prevent undesired outflow of drilling fluid into the formation or inflow of fluid from the formation into the borehole. The borehole is drilled in intervals whereby a casing which is to be installed in a lower borehole interval is lowered through a previously installed casing of an upper borehole interval. As a consequence of this procedure the casing of the lower interval is of smaller diameter than the casing of the upper interval. Thus, the casings are in a nested arrangement with casing diameters decreasing in downward direction. Cement annuli are provided between the outer surfaces of the casings and the borehole wall to seal the casings from the borehole wall. As a consequence of this nested arrangement a relatively large borehole diameter is required at the upper part of the wellbore. Such a large borehole diameter involves increased costs due

to heavy casing handling equipment, large drill bits and increased volumes of drilling fluid and drill cuttings. Moreover, increased drilling rig time is involved due to required cement pumping, cement hardening, required equipment changes due to large variations in hole diameters drilled in the course of the well, and the large volume of cuttings drilled and removed.

[005] During oil exploration, a wellbore typically traverses a number of zones within a subterranean formation. Wellbore casings are then formed in the wellbore by radially expanding and plastically deforming tubular members that are coupled to one another by threaded connections existing methods for radially expanding and plastically deforming tubular members coupled to one another by threaded connections are not always reliable and do not always produce satisfactory results. In particular, the threaded connections can be damaged during the radial expansion process. Furthermore, the threaded connections between adjacent tubular members, whether radially expanded or not, are typically not sufficiently coupled to permit the transmission of energy through the tubular members from the surface to the downhole location. Further, the damaged threads may permit undesirable leakage between the inside of the casing and the exterior of the casing.

[006] The present invention is directed to overcoming one or more of the limitations of the existing procedures for forming and/or repairing wellbore casings.

#### **Summary of the Invention**

[007] According to one aspect of the present invention, an assembly is provided that includes a first tubular member including external threads, and a second tubular member comprising internal threads coupled to the external threads of the first tubular member. At least one of the first and second tubular members define one or more stress concentrators. According to another aspect of the present invention, a method for forming a wellbore casing has been described that includes positioning any one, portion, or combination, of the exemplary embodiments of the assemblies of the present application within a borehole that traverses a subterranean formation, and radially expanding and plastically deforming the assembly within the borehole.

[008] According to another aspect of the present invention, an apparatus is provided that includes a wellbore that traverses a subterranean formation, and a wellbore casing positioned within and coupled to the wellbore. The wellbore casing is coupled to the wellbore by a process including: positioning any one, portion, or combination, of the exemplary assemblies of the present application within the wellbore, and radially expanding and plastically deforming the assembly within the wellbore.

[009] According to another aspect of the present invention, a system for forming a wellbore casing is provided that includes means for positioning any one, portion, or combination, of the exemplary assemblies of the present application within a borehole that traverses a subterranean formation, and means for radially expanding and plastically deforming the assembly within the borehole.

[0010] According to another aspect of the present invention, a method of providing a fluid tight seal between a pair of overlapping tubular members is provided that includes forming one or more stress

concentrators within at least one of the tubular members, and radially expanding and plastically deforming the tubular members.

#### Brief Description of the Drawings

[0011] Fig. 1 is a fragmentary cross-sectional illustration of a first tubular threadably coupled to a second tubular.

[0012] Fig. 2 is a fragmentary cross-sectional illustration of a first tubular threadably coupled to a second tubular.

#### Detailed Description of the Illustrative Embodiments

[0013] Fig. 1 illustrates a first tubular member 10 that defines a passage 10a that includes a pin member 12 that includes stress concentration grooves, 14a and 14b, formed in the internal surface of the pin member, and external threads 16 that engage internal threads 18 of a box member 20 of a second tubular member 22 that defines a passage 22a. Stress concentration grooves, 24a and 24b, are formed in the external surface of the box member 20 of the second tubular member, and an external sleeve 26 is coupled to and overlaps with the ends of the first and second tubular members, 10 and 22. The first tubular member 10, the second tubular member 22, and the external sleeve 26 may be radially expanded and plastically deformed using any number of conventional methods and apparatus and/or as disclosed in one or more of the following: (1) U.S. patent application serial no. 09/454,139, attorney docket no. 25791.03.02, filed on 12/3/1999, (2) U.S. patent application serial no. 09/510,913, attorney docket no. 25791.7.02, filed on 2/23/2000, (3) U.S. patent application serial no. 09/502,350, attorney docket no. 25791.8.02, filed on 2/10/2000, (4) U.S. patent no. 6,328,113, (5) U.S. patent application serial no. 09/523,460, attorney docket no. 25791.11.02, filed on 3/10/2000, (6) U.S. patent application serial no. 09/512,895, attorney docket no. 25791.12.02, filed on 2/24/2000, (7) U.S. patent application serial no. 09/511,941, attorney docket no. 25791.16.02, filed on 2/24/2000, (8) U.S. patent application serial no. 09/588,946, attorney docket no. 25791.17.02, filed on 6/7/2000, (9) U.S. patent application serial no. 09/559,122, attorney docket no. 25791.23.02, filed on 4/26/2000, (10) PCT patent application serial no. PCT/US00/18635, attorney docket no. 25791.25.02, filed on 7/9/2000, (11) U.S. provisional patent application serial no. 60/162,671, attorney docket no. 25791.27, filed on 11/1/1999, (12) U.S. provisional patent application serial no. 60/154,047, attorney docket no. 25791.29, filed on 9/16/1999, (13) U.S. provisional patent application serial no. 60/159,082, attorney docket no. 25791.34, filed on 10/12/1999, (14) U.S. provisional patent application serial no. 60/159,039, attorney docket no. 25791.36, filed on 10/12/1999, (15) U.S. provisional patent application serial no. 60/159,033, attorney docket no. 25791.37, filed on 10/12/1999, (16) U.S. provisional patent application serial no. 60/212,359, attorney docket no. 25791.38, filed on 6/19/2000, (17) U.S. provisional patent application serial no. 60/165,228, attorney docket no. 25791.39, filed on 11/12/1999, (18) U.S. provisional patent application serial no. 60/221,443, attorney docket no. 25791.45, filed on 7/28/2000, (19) U.S. provisional patent application serial no. 60/221,645, attorney

docket no. 25791.46, filed on 7/28/2000, (20) U.S. provisional patent application serial no. 60/233,638, attorney docket no. 25791.47, filed on 9/18/2000, (21) U.S. provisional patent application serial no. 60/237,334, attorney docket no. 25791.48, filed on 10/2/2000, (22) U.S. provisional patent application serial no. 60/270,007, attorney docket no. 25791.50, filed on 2/20/2001, (23) U.S. provisional patent application serial no. 60/262,434, attorney docket no. 25791.51, filed on 1/17/2001, (24) U.S. provisional patent application serial no. 60/259,486, attorney docket no. 25791.52, filed on 1/3/2001, (25) U.S. provisional patent application serial no. 60/303,740, attorney docket no. 25791.61, filed on 7/6/2001, (26) U.S. provisional patent application serial no. 60/313,453, attorney docket no. 25791.59, filed on 8/20/2001, (27) U.S. provisional patent application serial no. 60/317,985, attorney docket no. 25791.67, filed on 9/6/2001, (28) U.S. provisional patent application serial no. 60/3318,386, attorney docket no. 25791.67.02, filed on 9/10/2001, (29) U.S. utility patent application serial no. 09/969,922, attorney docket no. 25791.69, filed on 10/3/2001, (30) U.S. utility patent application serial no. 10/016,467, attorney docket no. 25791.70, filed on 12/10/2001, (31) U.S. provisional patent application serial no. 60/343,674, attorney docket no. 25791.68, filed on 12/27/2001, (32) U.S. provisional patent application serial no. 60/346,309, attorney docket no. 25791.92, filed on 1/7/2002, (33) U.S. provisional patent application serial no. 60/372,048, attorney docket no. 25791.93, filed on 4/12/2002, (34) U.S. provisional patent application serial no. 60/380,147, attorney docket no. 25791.104, filed on 5/6/2002, (35) U.S. provisional patent application serial no. 60/387,486, attorney docket no. 25791.107, filed on 6/10/2002, (36) U.S. provisional patent application serial no. 60/387,961, attorney docket no. 25791.108, filed on 6/12/2002, (37) U.S. provisional patent application serial no. 60/394,703, attorney docket no. 25791.90, filed on 6/26/2002, (38) U.S. provisional patent application serial no. 60/397,284, attorney docket no. 25791.106, filed on 7/19/2002, (39) U.S. provisional patent application serial no. 60/398,061, attorney docket no. 25791.110, filed on 7/24/2002, (40) U.S. provisional patent application serial no. 60/405,610, attorney docket no. 25791.119, filed on 8/23/2002, (41) U.S. provisional patent application serial no. 60/405,394, attorney docket no. 25791.120, filed on 8/23/2002, (42) U.S. provisional patent application serial no. 60/412,177, attorney docket no. 25791.117, filed on 9/20/2002, (43) U.S. provisional patent application serial no. 60/412,653, attorney docket no. 25791.118, filed on 9/20/2002, (44) U.S. provisional patent application serial no. 60/412,544, attorney docket no. 25791.121, filed on 9/20/2002, (45) U.S. provisional patent application serial no. 60/412,187, attorney docket no. 25791.128, filed on 9/20/2002, (46) U.S. provisional patent application serial no. 60/412,196, attorney docket no. 25791.127, filed on 9/20/2002, (47) U.S. provisional patent application serial no. 60/412,542, attorney docket no. 25791.102, filed on 9/20/2002, (48) U.S. provisional patent application serial no. 60/412,487, attorney docket no. 25791.112, filed on 9/20/2002, (49) U.S. provisional patent application no. 60/412,488, attorney docket no. 25791.114, filed on 9/20/2002, the disclosures of which are incorporated herein by reference.

[0014] In an exemplary embodiment, during the radial expansion and plastic deformation of the first tubular member 10, the second tubular member 22, and the external sleeve 26, the stress concentration grooves, 14a, 14b, 24a, and 24b, concentrate compressive stresses onto the threads, 16 and 18, of the pin and box members, 12 and 20, of the first and second tubular members to drive the threads together to thereby provide a fluid tight seal between the threads of the pin and box members of the first and second tubular members upon the completion of the radial expansion and plastic deformation.

[0015] Fig. 2 is an illustration of another illustrative embodiment.

[0016] An assembly has been described that includes a first tubular member including external threads, and a second tubular member comprising internal threads coupled to the external threads of the first tubular member. At least one of the first and second tubular members define one or more stress concentrators. In an exemplary embodiment, the assembly further comprises an external sleeve coupled to and overlapping with the ends of the first and second tubular members. In an exemplary embodiment, one or more of the stress concentrators comprise surface grooves formed in the surfaces of at least one of the first and second tubular members. In an exemplary embodiment, the stress concentrators are defined above the internal and external threads of the first and second tubular members.

[0017] A method for forming a wellbore casing has been described that includes positioning any one, portion, or combination, of the exemplary embodiments of the assemblies of the present application within a borehole that traverses a subterranean formation, and radially expanding and plastically deforming the assembly within the borehole.

[0018] An apparatus has been described that includes a wellbore that traverses a subterranean formation, and a wellbore casing positioned within and coupled to the wellbore. The wellbore casing is coupled to the wellbore by a process including: positioning any one, portion, or combination, of the exemplary assemblies of the present application within the wellbore, and radially expanding and plastically deforming the assembly within the wellbore.

[0019] A system for forming a wellbore casing has been described that includes means for positioning any one, portion, or combination, of the exemplary assemblies of the present application within a borehole that traverses a subterranean formation, and means for radially expanding and plastically deforming the assembly within the borehole.

[0020] A method of providing a fluid tight seal between a pair of overlapping tubular members has been described that includes forming one or more stress concentrators within at least one of the tubular members, and radially expanding and plastically deforming the tubular members. In an exemplary embodiment, the tubular members are threadably coupled, and the stress concentrators are formed above the threaded coupling.

[0021] In an exemplary embodiment, the stress concentrators comprise surface grooves formed in at least one of the tubular members.

[0022] It is understood that variations may be made in the foregoing without departing from the scope of



the invention. For example, the teachings of the present illustrative embodiments may be used to provide an insulated wellbore casing, a pipeline, or a structural support. Furthermore, the elements and teachings of the various illustrative embodiments may be combined in whole or in part in some or all of the illustrative embodiments. In addition, the external sleeve 26 may be omitted. Furthermore, one or more of the stress concentration grooves, 14a, 14b, 24a, and/or 24b, may be omitted. In addition, the stress concentration grooves, 14a, 14b, 24a, and/or 24b may be provided in any geometric shape capable of concentrating stresses. Furthermore, the stress concentration grooves, 14a and 14b, may or may not be positioned in opposing relation to the stress concentration grooves, 24a and 24b. In addition, the first and second tubular members, 10 and 22, may or may not be threadably coupled to one another, and the threads, 16 and 18, of the first and second tubular members may be any type of threads.

[0023] Although illustrative embodiments of the invention have been shown and described, a wide range of modification, changes and substitution is contemplated in the foregoing disclosure. In some instances, some features of the present invention may be employed without a corresponding use of the other features. Accordingly, it is appropriate that the appended claims be construed broadly and in a manner consistent with the scope of the invention.

### Claims

1. An assembly, comprising:  
a first tubular member comprising external threads; and  
a second tubular member comprising internal threads coupled to the external threads of the first tubular member;  
wherein at least one of the first and second tubular members define one or more stress concentrators.
2. The assembly of claim 1, further comprising:  
an external sleeve coupled to and overlapping with the ends of the first and second tubular members.
3. The assembly of claim 1, wherein one or more of the stress concentrators comprise surface grooves formed in the surfaces of at least one of the first and second tubular members.
4. The assembly of claim 1, wherein the stress concentrators are defined above the internal and external threads of the first and second tubular members.
5. A method for forming a wellbore casing, comprising:  
positioning the assembly of claim 1 within a borehole that traverses a subterranean formation; and  
radially expanding and plastically deforming the assembly within the borehole.
6. A method for forming a wellbore casing, comprising:  
positioning the assembly of claim 2 within a borehole that traverses a subterranean formation; and  
radially expanding and plastically deforming the assembly within the borehole.
7. A method for forming a wellbore casing, comprising:  
positioning the assembly of claim 3 within a borehole that traverses a subterranean formation; and  
radially expanding and plastically deforming the assembly within the borehole.
8. A method for forming a wellbore casing, comprising:  
positioning the assembly of claim 4 within a borehole that traverses a subterranean formation; and  
radially expanding and plastically deforming the assembly within the borehole.
9. An apparatus, comprising:  
a wellbore that traverses a subterranean formation; and  
a wellbore casing positioned within and coupled to the wellbore;  
wherein the wellbore casing is coupled to the wellbore by a process comprising:  
positioning the assembly of claim 1 within the wellbore; and  
radially expanding and plastically deforming the assembly within the wellbore.
10. An apparatus, comprising:  
a wellbore that traverses a subterranean formation; and  
a wellbore casing positioned within and coupled to the wellbore;  
wherein the wellbore casing is coupled to the wellbore by a process comprising:

- positioning the assembly of claim 2 within the wellbore; and  
radially expanding and plastically deforming the assembly within the wellbore.
11. An apparatus, comprising:  
a wellbore that traverses a subterranean formation; and  
a wellbore casing positioned within and coupled to the wellbore;  
wherein the wellbore casing is coupled to the wellbore by a process comprising:  
positioning the assembly of claim 3 within the wellbore; and  
radially expanding and plastically deforming the assembly within the wellbore.
12. An apparatus, comprising:  
a wellbore that traverses a subterranean formation; and  
a wellbore casing positioned within and coupled to the wellbore;  
wherein the wellbore casing is coupled to the wellbore by a process comprising:  
positioning the assembly of claim 4 within the wellbore; and  
radially expanding and plastically deforming the assembly within the wellbore.
15. A system for forming a wellbore casing, comprising:  
means for positioning the assembly of claim 1 within a borehole that traverses a subterranean  
formation; and  
means for radially expanding and plastically deforming the assembly within the borehole.
16. A system for forming a wellbore casing, comprising:  
means for positioning the assembly of claim 2 within a borehole that traverses a subterranean  
formation; and  
means for radially expanding and plastically deforming the assembly within the borehole.
17. A system for forming a wellbore casing, comprising:  
means for positioning the assembly of claim 3 within a borehole that traverses a subterranean  
formation; and  
means for radially expanding and plastically deforming the assembly within the borehole.
18. A system for forming a wellbore casing, comprising:  
means for positioning the assembly of claim 4 within a borehole that traverses a subterranean  
formation; and  
means for radially expanding and plastically deforming the assembly within the borehole.
19. A method of providing a fluid tight seal between a pair of overlapping tubular members,  
comprising:  
forming one or more stress concentrators within at least one of the tubular members; and  
radially expanding and plastically deforming the tubular members.
20. The method of claim 19, wherein the tubular members are threadably coupled; and  
wherein the stress concentrators are formed above the threaded coupling.

21. The method of claim 19, wherein the stress concentrators comprise surface grooves formed in at least one of the tubular members.

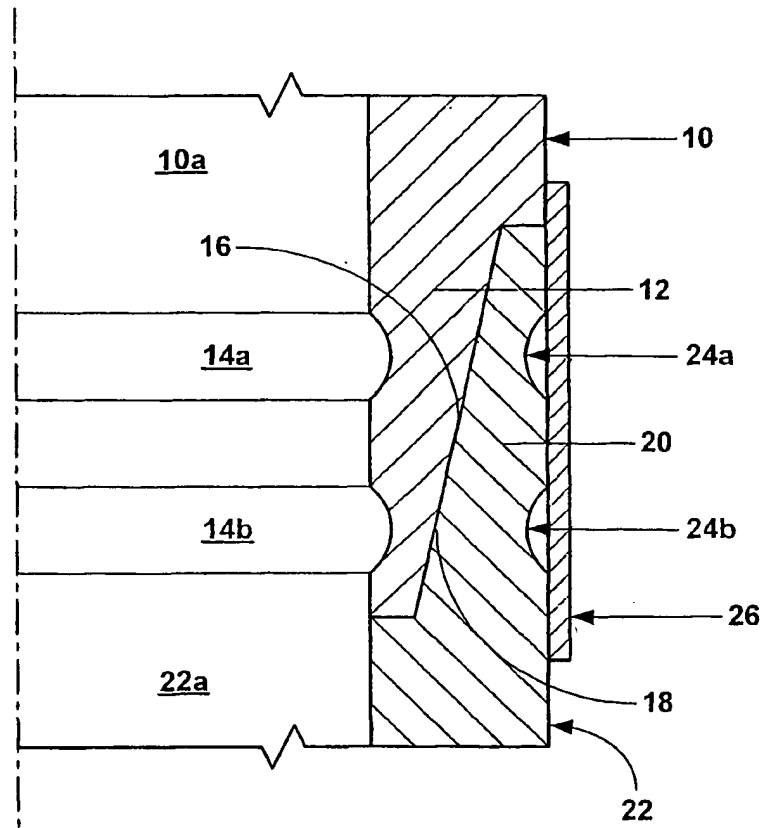

Fig. 1

29 AUGUST 2002  
Jose R. MENCHACA, JR August 29, 2002  
Jose R. MENCHACA, JR

29 AUGUST 2002

Scott Costa  
Scott Costa



By Controlling "Necking" or Movement  
of Material during the expansion  
Process, induced stress (contacts)  
can occur at the Box/PIN thread  
interface.  
Create varying cross-sectional  
areas over the threads to  
induce contact pressure during  
"after expansion" process.

KNOWN:

- 1) MAT EXP %
- 2) ARC EXP
- 3) Necking
- 4) Necking

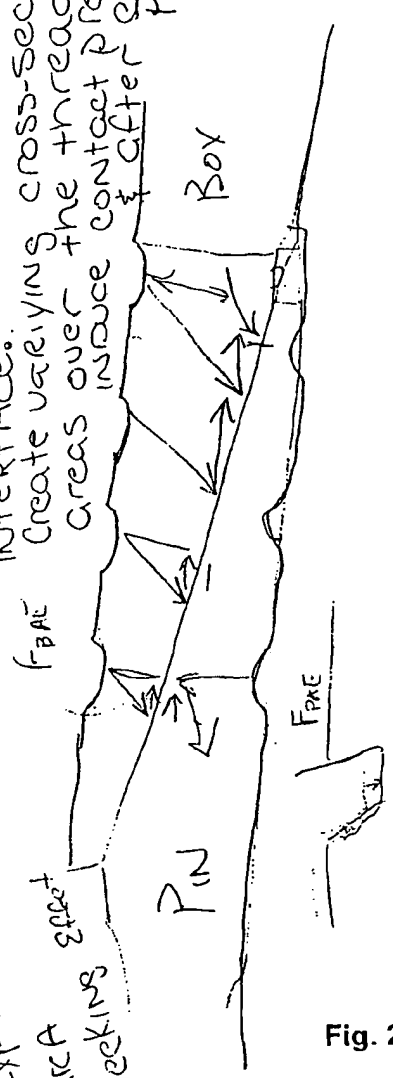

Fig. 2

